



Shown with Kuzma 4Point Tonearm

# Kuzma Stabi M Turntable

# Stabi M is a special triple suspended turntable with a lid and DC motor.

The turntable combines the advantages of suspended and non suspended designs as well as the benefits of idler drives.

The top plate is insulated from the outer frame by four suspension towers with very low damped resonance. Below this plate is a decoupled main, uniquely shaped, carrier frame, built from massive aluminium blocks. This holds the platter bearing and massive aluminium armboard.

Below the top plate is also mounted a decoupled brass motor tower. The motor itself is damped with a solid brass cup and again decoupled inside a brass tower.

The motor is firmly fixed in relationship to the platter so as to ensure uniform platter drive and, in addition, is triple insulated (decoupled) from the platter bearing and armboard, so no motor noise affects the record or cartridge.

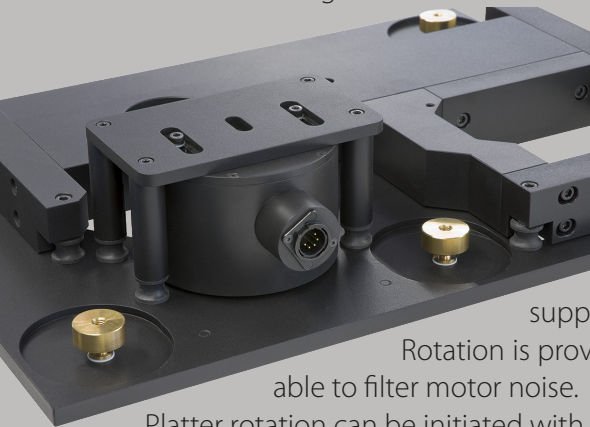
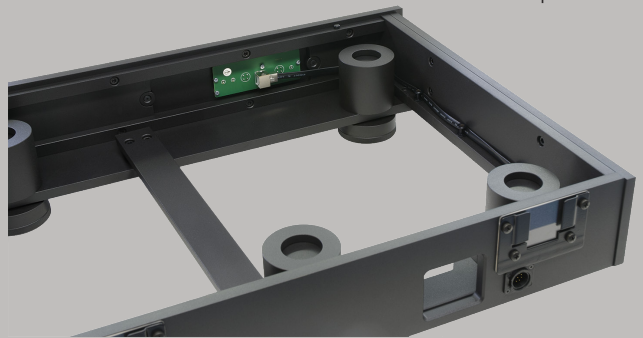

The main structure (top plate, main frame, motor tower, armboard) without the platter weighs 20 kg and because of very low system resonance, is better insulated from stand or room than most isolation platforms can provide.

Horizontal levelling of the top plate is via four buttons on the top.

Drive from the DC three phase motor is controlled by an external power supply, while the control panel is built into the turntable's massive front panel.

Rotation is provided by a stiff polyamide belt, which ensures stable platter drive and is still able to filter motor noise. The 12 kg heavy platter takes less than 3 seconds to full 33rpm speed.

Platter rotation can be initiated with the remote control.

The outer turntable frame and panels are made from aluminium plates. Most parts are bolted together, which gives damping and eliminates ringing of all parts.

The frame supports suspension towers and spiked legs for levelling.

The acrylic lid offers protection from dust and cartridge damage even when used with 12 inch long tonearms



## Technical data:

<b>Mass:</b>	60 kg
<b>Dimensions:</b>	600 x 500 x 280 mm
<b>Subchassis mass:</b>	20 kg (without platter)
<b>Platter:</b>	12 kg
<b>Motor:</b>	DC three phase, outboard power supply
<b>Speed control:</b>	33, 45, 78 rpm
<b>Belt:</b>	polyamide stiff belt
<b>Armboard:</b>	2 kg
<b>Suspension:</b>	triple elastics levels
<b>Horizontal chassis:</b>	yes
<b>Horizontal turntable levelling:</b>	yes (spikes in cups)

